



FRASTE MULTIDRILL SL

Geotechnical Drill Rig

The Fraste SL is a powerful drill rig in an incredibly small footprint. Measuring at just 4' wide and weighing in at only 6,613 lbs., the SL is the ideal "grab and go" rig. Despite the pocket-sized dimensions, the SL boasts a max torque of 3,319 ft lb. and enough power to tackle many different applications. Not only can the SL fit just about anywhere you need it to go, but it can also even be optioned out as a low-clearance rig!

QUICK SPECS:

- » Diesel Engine: CAT C1.7, 48 Hp
- » Emissions: Stage V, Tier 4F, non-DEF
- » Rotary Head Stroke: 5.9 - 9.2 ft
- » Pull-up: 5,620 lbf
- » Pull-down: 5,620 lbf
- » Max Rotary Head Torque: 3,319 ft lb
- » Max Rotary Head Speed: 900 rpm
- » Clamp Diameter: 1.9 - 8.3 in
- » Weight: 6,613 lbs
- » Tower Height: 16.7'
- » L x W x H (Stowed): 16.2' x 4' x 7.5'

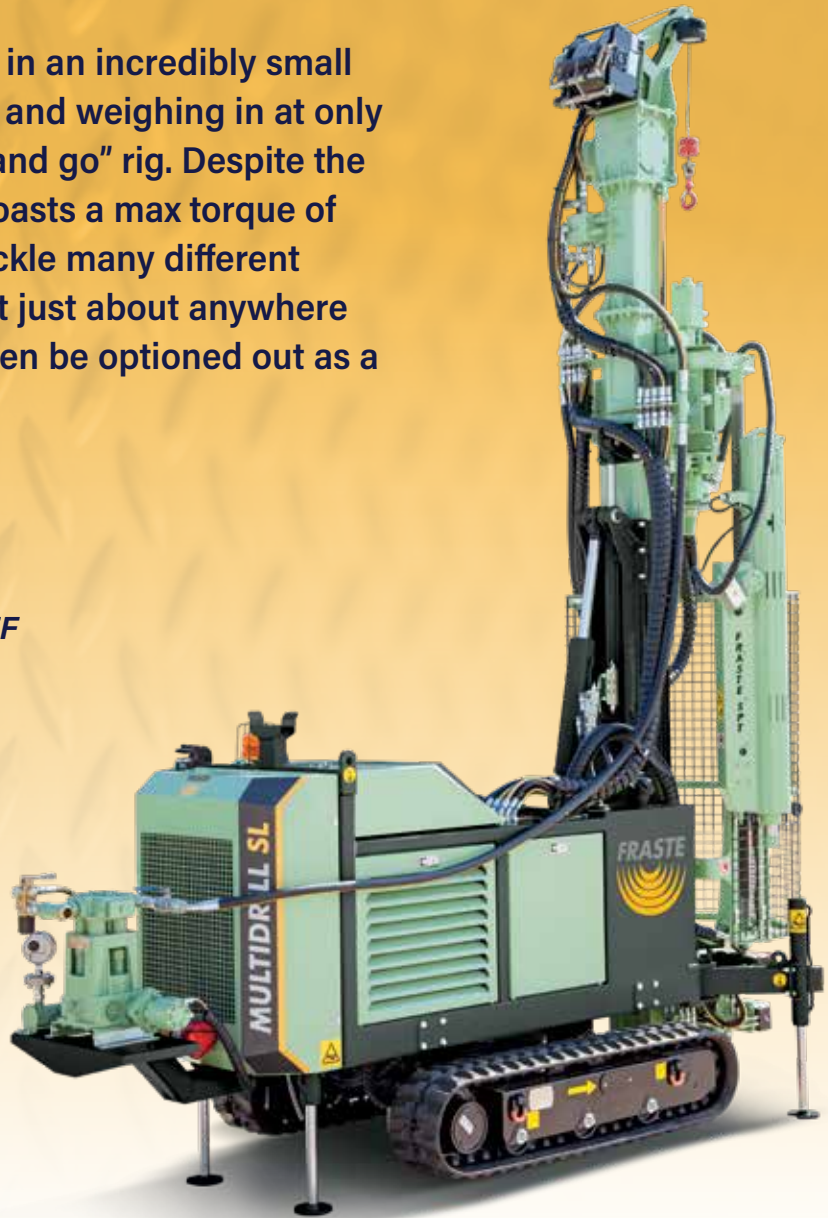



Fraste Multidrill SL Specs:

Hydraulic Rotary Head Options

	1 st speed		2 nd speed		3 rd speed		4 th speed	
	ft/lb	rpm	ft/lb	rpm	ft/lb	rpm	ft/lb	rpm
option 1	206	900	413	450	848	210	1696	105
option 2	258	730	516	365	1032	180	2065	90
option 3*	302	610	604	305	1290	150	2581	75
option 4	405	460	811	230	1659	110	3319	55

*standard configuration

Power Source

Diesel Engine: CAT C1.7, 48 Hp
Emissions: Stage V, Tier 4F, non-DEF

Mast

Rotary head stroke: 5.9 - 9.2 ft
Pull-up: 5,620 lbf
Pull-down: 5,620 lbf

Weight & Dimensions

Weight: 6,613 lbs
Tower Height: 16.7'
L x W x H (Stowed, ft): 16.2' x 4' x 7.5'

Clamp Diameter: 1.9 - 8.3 in

Standard Features

Main Winch 2,250 lbf, 110 ft/min
Quadraplex Piston Pump: ,21gpm, 580 psi
Hydraulic SPT Device: 30", 140 lbf
Hydraulic Percussion Hammer for Direct Push Sampling
Radio Remote Control
Hydraulic Air Valve
Mast Extension

Optional Equipment

Duplex Pump: 9 gpm, 550 psi
Screw Pump: 132 gpm, 116 psi
Foam Pump: 9 gpm, 550 psi
Line Lubricator: 2.25 gpm

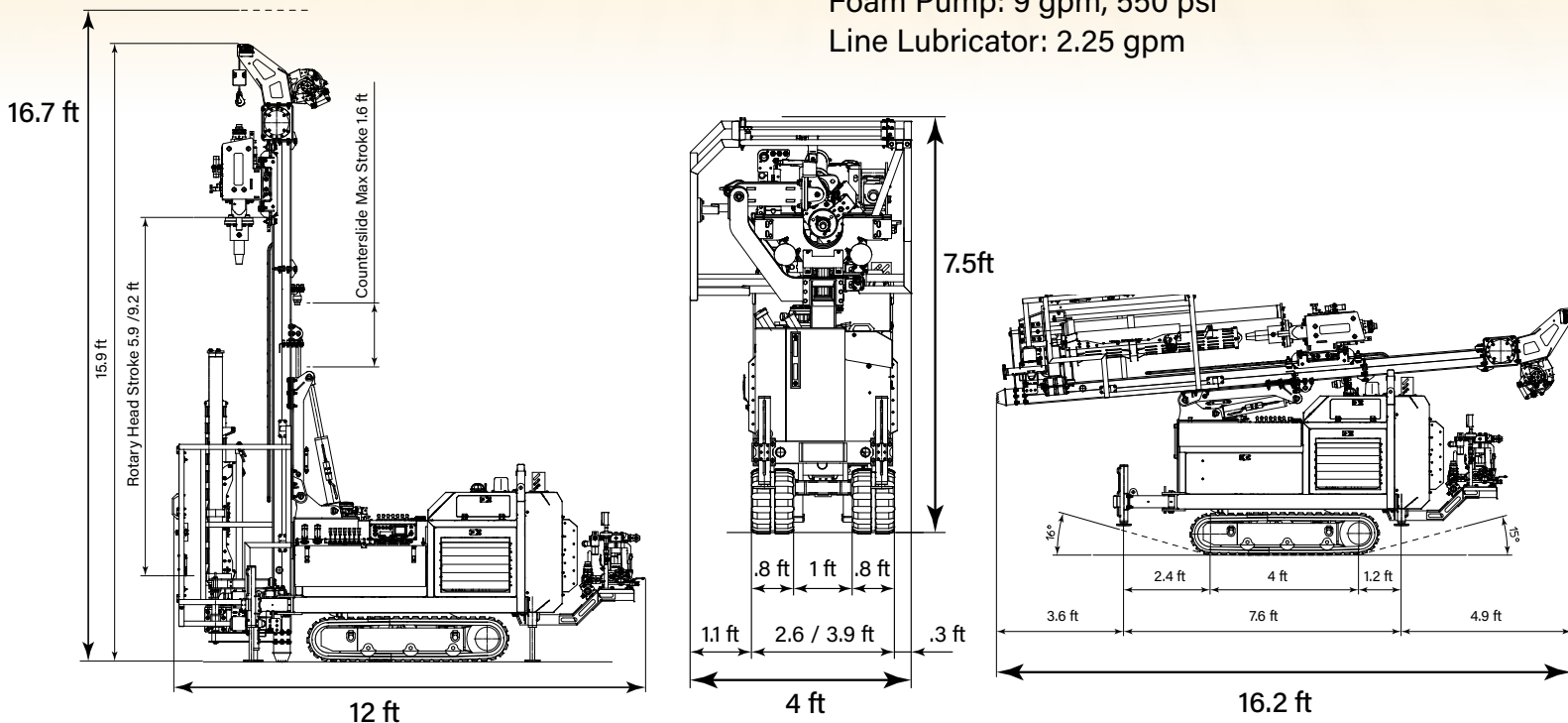

*Specifications may change without notice.



rigsourceinc.com | info@rigsourceinc.com | 630.365.1649